

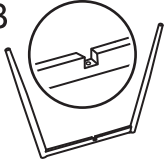

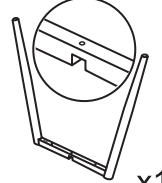

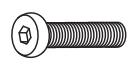



A  x1	B  x1	C  x1	D  M6x35 x4	E  Ø6xØ16 x5
F  M6x30 x1	H  5# x1			

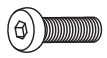

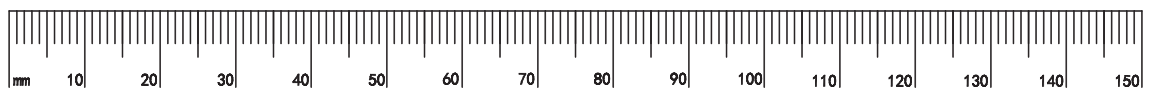
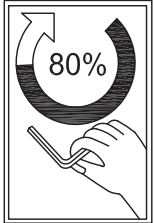
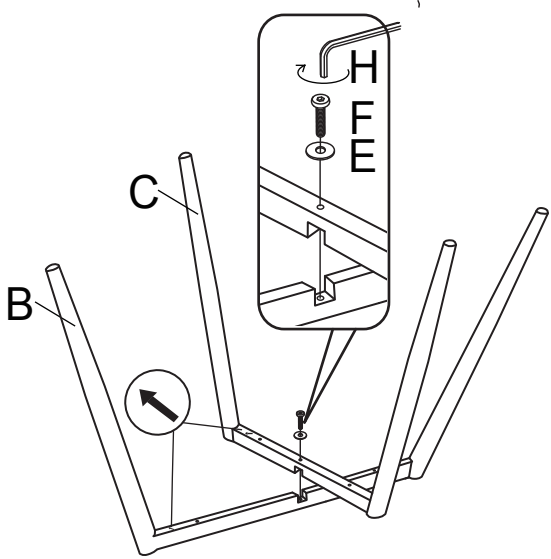



1

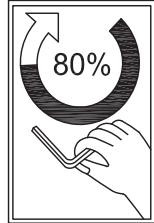
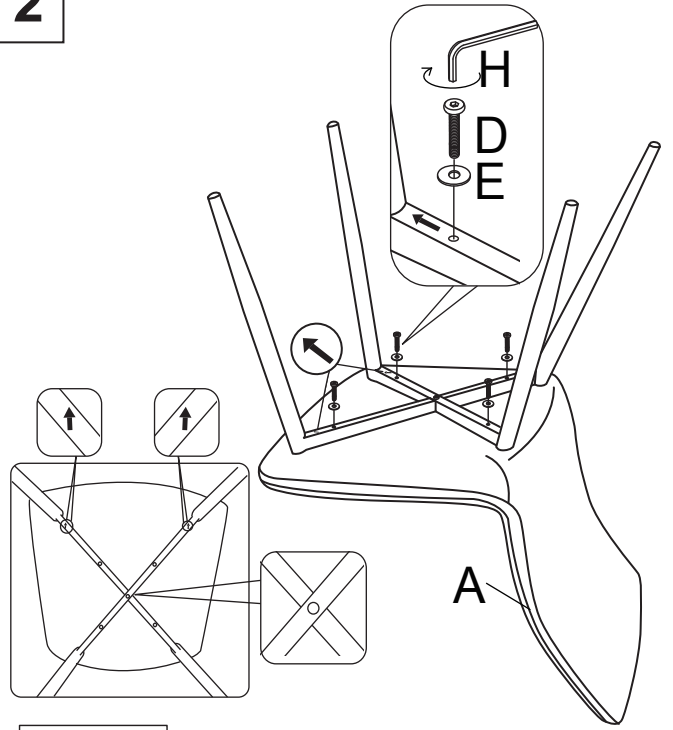

F	E	H
		
M6x30 x1	Ø6xØ16 x1	5# x1

2



D	E	H
		
M6x35 x4	Ø6xØ16 x4	5# x1

3

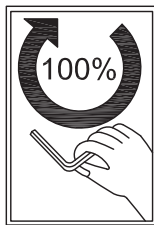
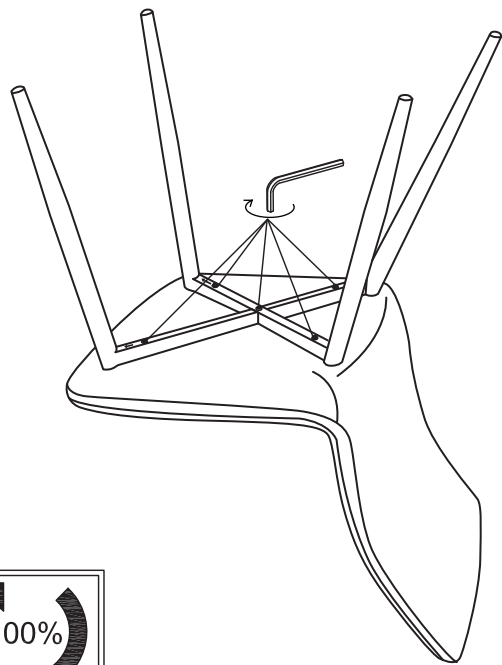

4

